

PERGOFAST

SISTEMA MODULAR PARA PÉRGULAS E MÓVEIS

- Permite a realização de pérgulas e móveis de qualquer forma e dimensão
- São suficientes componentes de madeira com secção quadrada sem qualquer tipo de maquinaria. Dimensões 90 x 90 mm (4" x 4"), 120 x 120mm, 140 x 140 mm (6" x 6")
- A galvanização e a pintura preta RAL9005FT garantem uma durabilidade e uma estética ótimas. Os parafusos incluídos são pintados a condizer

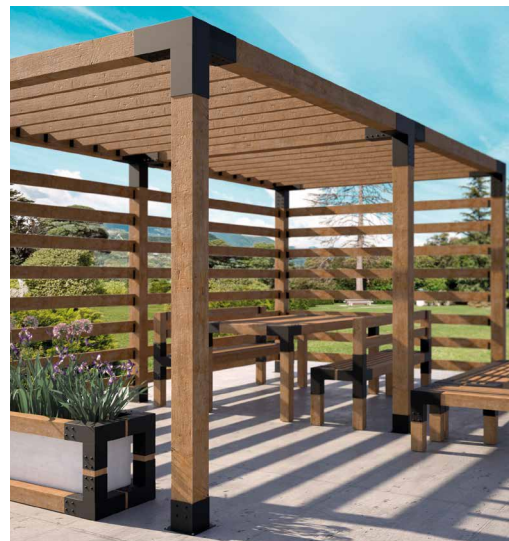

VIDEO

CLASSE DE SERVIÇO

SC3

MATERIAL

S235
THERMO
DUST

PERGO3WAY

CÓDIGO	copo [mm]	comprimento do braço [mm]	espessura [mm]	furos [n. x mm]	pçs
PERGO3W090	92 x 92	140	2,0	24 x Ø6,5	4
PERGO3W120	121 x 121	190	2,0	36 x Ø6,5	4
PERGO3W140	143 x 143	250	2,0	48 x Ø6,5	4

Parafusos pintados para madeira incluídos.



PERGO4WAY

CÓDIGO	copo [mm]	comprimento do braço [mm]	espessura [mm]	furos [n. x mm]	pçs
PERGO4W090	92 x 92	140	2,0	32 x Ø6,5	2
PERGO4W120	121 x 121	190	2,0	48 x Ø6,5	2
PERGO4W140	143 x 143	250	2,0	64 x Ø6,5	2

Parafusos pintados para madeira incluídos.

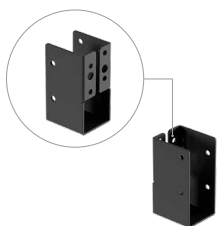

PERGOSHOE

CÓDIGO	base [mm]	altura [mm]	espessura [mm]	furos [n. x mm]	pçs
PERGOSHOE4090	40	90	2	8 x Ø6,5	16

Parafusos pintados para madeira incluídos.

















LIFT25

PERGOPOST

CÓDIGO	copo [mm]	altura [mm]	espessura [mm]	chapa da base [mm]	furos na base [n. x mm]	furos no copo [n. x mm]	pçs
PERGOPOST090B	92 x 92	150	2,0	150 x 150	4 x Ø11,5	8 x Ø6,5	1
PERGOPOST120B	121 x 121	150	2,0	200 x 200	4 x Ø11,5	8 x Ø6,5	1
PERGOPOST140B	143 x 143	150	2,0	200 x 200	4 x Ø11,5	8 x Ø6,5	1
LIFT25	60 x 60	25	3,0	-	-	-	1

LIFT não incluídos na embalagem.
Parafusos pintados para madeira incluídos.

PÉRGULA SIMPLES COM PROTEÇÃO SOLAR

opção 1	opção 2	opção 3
 90x90 mm (4"x4")	 120x120 mm (4 3/4"x4 3/4")	 140x140 mm (6"x6")
 4x PERGOPOST090B	 4x PERGOPOST120B	 4x PERGOPOST140B
 4x PERGO3W090	 4x PERGO3W120	 4x PERGO3W140
 16x PERGOSHOE4090(*)	 16x PERGOSHOE4090(*)	 16x PERGOSHOE4090(*)
 4x LIFT25	 4x LIFT25	 4x LIFT25



















as opções propostas variam consoante a dimensão dos elementos de madeira



(*)A quantidade indicada refere-se ao número de barrotes colocados na cobertura ou na parede. Comprimentos sugeridos para os componentes de madeira numa pérgula de 300 cm x 300 cm:

- 4 colunas L = 250 cm
- 4 vigas L = 300 cm
- 8 proteções solares (40 mm x 90 mm) L = 298 cm

PÉRGULA DUPLA COM PROTEÇÃO SOLAR

opção 1	opção 2	opção 3
 90x90 mm (4"x4")	 120x120 mm (4 3/4"x4 3/4")	 140x140 mm (6"x6")
 6x PERGOPOST090B	 6x PERGOPOST120B	 6x PERGOPOST140B
 4x PERGO3W090	 4x PERGO3W120	 4x PERGO3W140
 2x PERGO4W090	 2x PERGO4W120	 2x PERGO4W140
 32x PERGOSHOE4090(*)	 32x PERGOSHOE4090(*)	 32x PERGOSHOE4090(*)
 6x LIFT25	 6x LIFT25	 6x LIFT25

as opções propostas variam consoante a dimensão dos elementos de madeira

















(*)a quantidade indicada refere-se ao número de barrotes colocados na cobertura ou na parede em relação a um vão.

Comprimentos sugeridos para os componentes de madeira numa pérgula de 300 cm x 600 cm:

- 6 colunas L = 250 cm
- 7 vigas L = 300 cm
- 16 proteções solares (40 mm x 90 mm) L=298 cm

PÉRGULA SIMPLES DE PAREDE COM PROTEÇÃO SOLAR

opção 1	opção 2	opção 3
 90x90 mm (4"x4")	 120x120 mm (4 3/4"x4 3/4")	 140x140 mm (6"x6")
 4x PERGOPOST090B	 4x PERGOPOST120B	 4x PERGOPOST140B
 2x PERGO3W090	 2x PERGO3W120	 2x PERGO3W140
 16x PERGOSH0E4090 ^(*)	 16x PERGOSH0E4090 ^(*)	 16x PERGOSH0E4090 ^(*)
 2x LIFT25	 2x LIFT25	 2x LIFT25



















(*)A quantidade indicada refere-se ao número de barrotes colocados na cobertura ou na parede. Comprimentos sugeridos para os componentes de madeira numa pérgula de 300 cm x 300 cm:

- 2 colunas L = 250 cm
- 3 vigas L = 300 cm
- 8 proteções solares (40 mm x 90 mm) L=298 cm

as opções propostas variam consoante a dimensão dos elementos de madeira



PÉRGULA DUPLA DE PAREDE COM PROTEÇÃO SOLAR

opção 1	opção 2	opção 3
 90x90 mm (4"x4")	 120x120 mm (4 3/4"x4 3/4")	 140x140 mm (6"x6")
 6x PERGOPOST090B	 6x PERGOPOST120B	 6x PERGOPOST140B
 2x PERGO3W090	 2x PERGO3W120	 2x PERGO3W140
 1x PERGO4W090	 1x PERGO4W120	 1x PERGO4W140
 32x PERGOSH0E4090 ^(*)	 32x PERGOSH0E4090 ^(*)	 32x PERGOSH0E4090 ^(*)
 3x LIFT25	 3x LIFT25	 3x LIFT25

(*)a quantidade indicada refere-se ao número de barrotes colocados na cobertura ou na parede em relação a um vão.





Comprimentos sugeridos para os componentes de madeira numa pérgula de 300 cm x 600 cm:

- 3 colunas L = 250 cm
- 5 vigas L = 300 cm
- 16 proteções solares (40 mm x 90 mm) L=298 cm

as opções propostas variam consoante a dimensão dos elementos de madeira



BANCO COM ENCOSTO

	 2x PERGO3W090	 2x PERGO4W090	 12x PERGOSH0E4090
---	--	--	--

- Comprimentos sugeridos para os componentes de madeira 200 cm x 50 cm
- 4 elementos verticais L = 40 cm
 - 2 correntes longitudinais (assento) L=200 cm e L=181,2 cm
 - 2 travessas (assento) L = 40 cm
 - 2 travessas (encosto) L = 40 cm
 - 6 elementos longitudinais (40 mm x 90 mm) L = 180 cm





BANCO

	 4x PERGO3W090	 8x PERGOSH0E4090
---	--	---

- Comprimentos sugeridos para os componentes de madeira 200 cm x 50 cm
- 4 elementos verticais L = 40 cm
 - 2 correntes longitudinais L = 200 cm
 - 2 travessas L = 30 cm
 - 4 elementos longitudinais (40 mm x 90 mm) L = 198 cm



MESA

	 4x PERGO3W090	 16x PERGOSH0E4090
---	--	--

- Comprimentos sugeridos para os componentes de madeira 200 cm x 100 cm:
- 4 elementos verticais L = 80 cm
 - 2 correntes longitudinais L = 200 cm
 - 8 elementos longitudinais (40 mm x 90 mm) L = 198 cm



CAIXA

	 8x PERGO3W090
---	--

- Comprimentos sugeridos para os componentes de madeira 200 cm x 50 cm:
- 4 elementos verticais L = 50 cm
 - 4 correntes longitudinais L = 200 cm
 - 4 travessas L = 30 cm

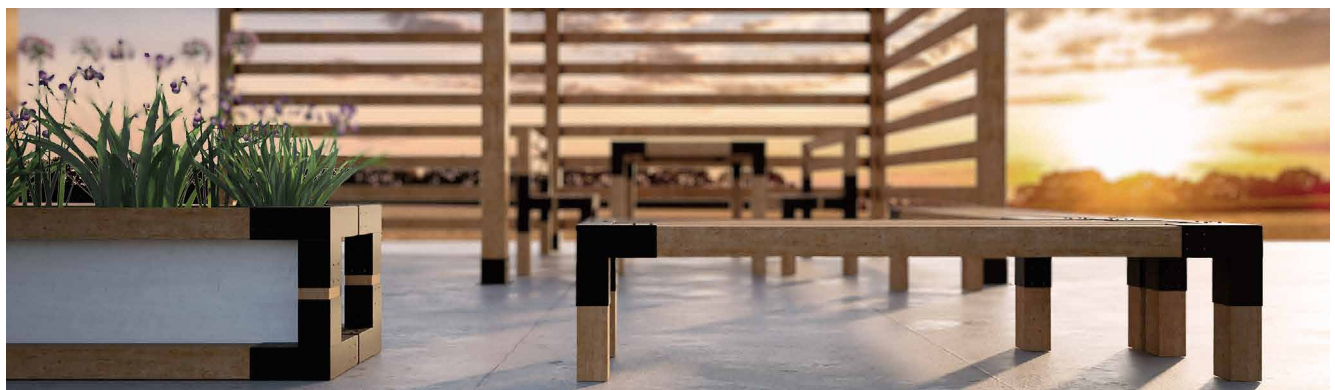
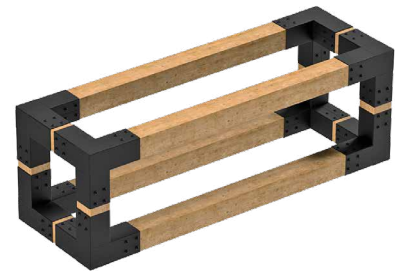

MONTAGEM

PÉRGULA SIMPLES COM PROTEÇÃO SOLAR

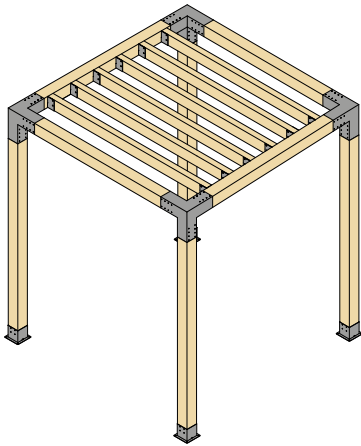

01 Colocar a parte superior da pérgula no lugar

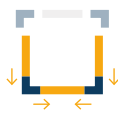
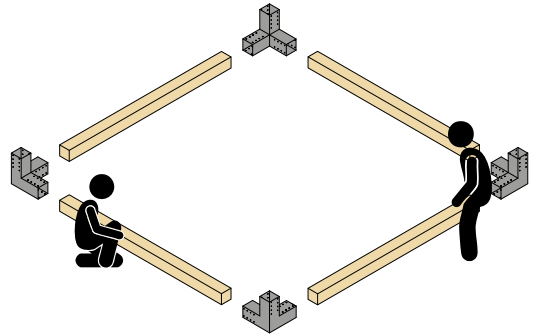

02a Montar primeiro os três elementos (de modo a formar um U)

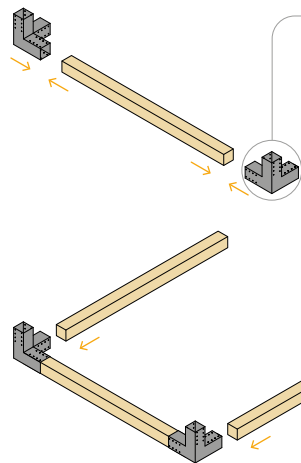

batente de posicionamento



02b Fixar com aparafusadora

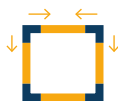
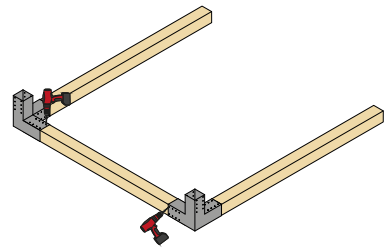

03a Completar a parte superior da pérgula

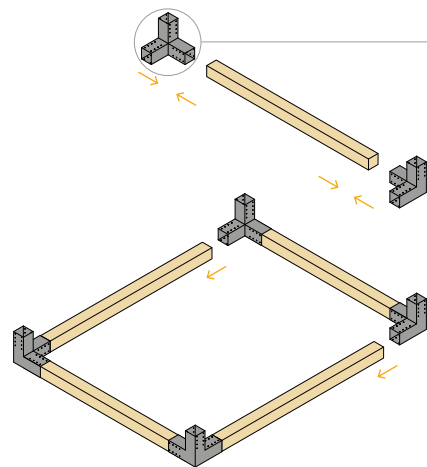

batente de posicionamento



03b Fixação e rotação da parte montada

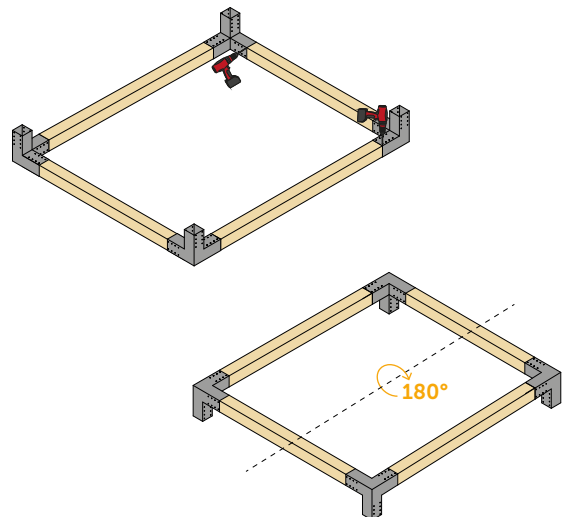



04
 Fixar as sapatas na viga

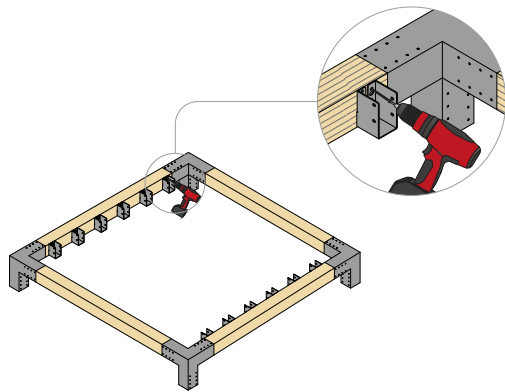

05
 Montar os porta-pilares

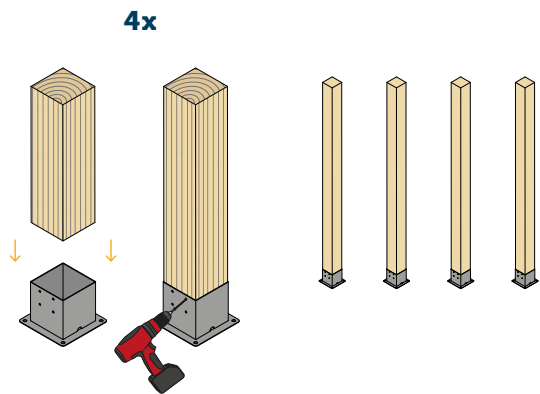

06
 Inserir os elementos verticais com os porta-pilares

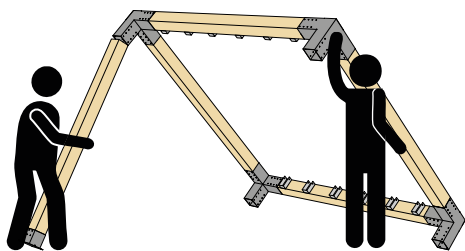

07
 Completar a operação inserindo os restantes elementos verticais e proceder à fixação

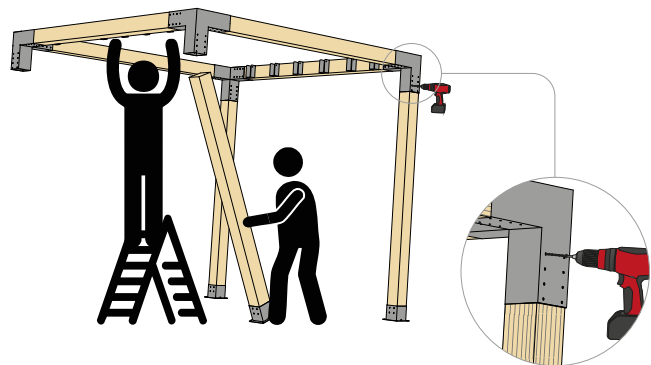

08
 Verificar a verticalidade dos elementos verticais e a esquadria da estrutura montada. Em seguida, fixar os porta-pilares ao solo

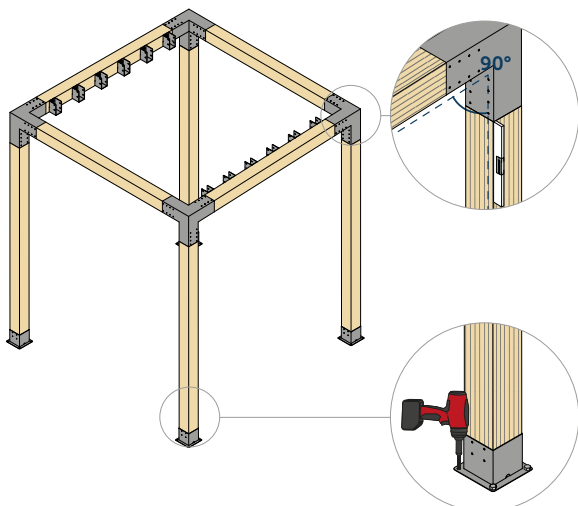

09
 Completar a montagem da estrutura com a fixação dos barros

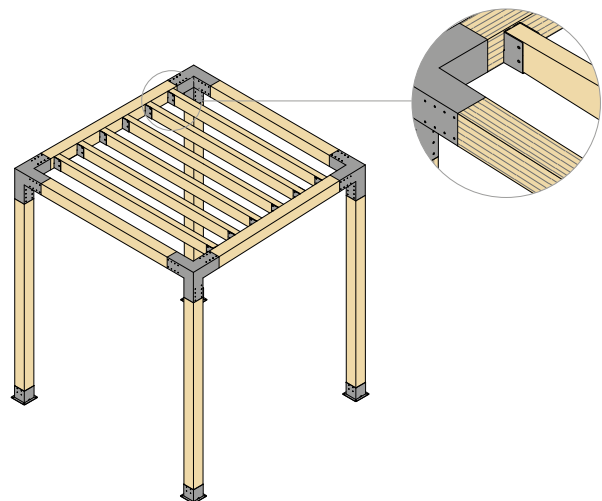

MONTAGEM

PÉRGULA SIMPLES DE PAREDE COM PROTEÇÃO SOLAR

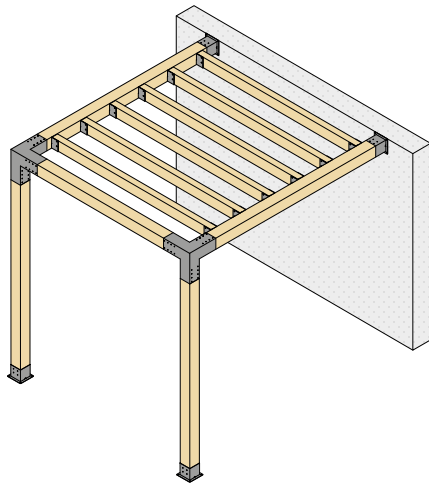

01
Colocar a parte superior da pérgula no lugar

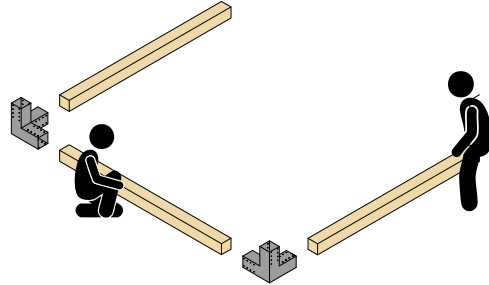

02a
Montar primeiro os três elementos (de modo a formar um U)

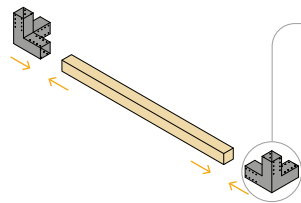

batente de posicionamento

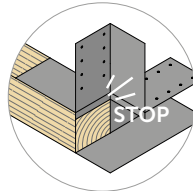
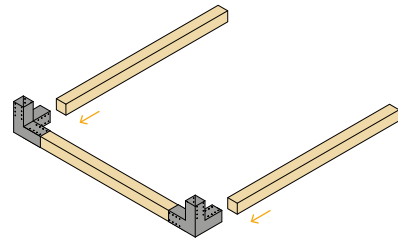
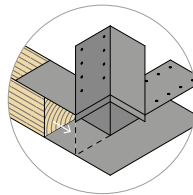

02b
Fixar com aparafusadora

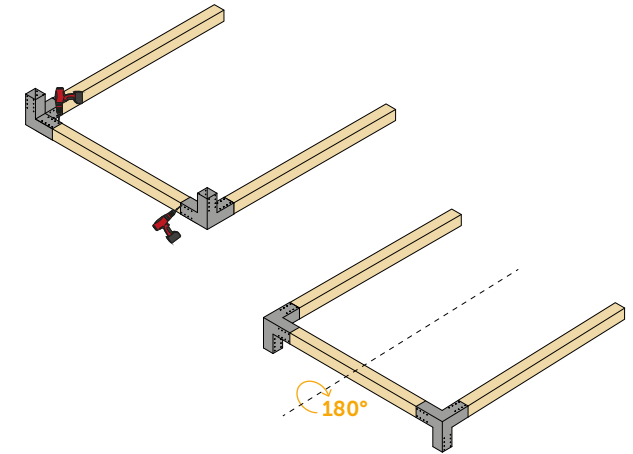

03
Montar as sapatas e os porta-pilares nas vigas como indicado

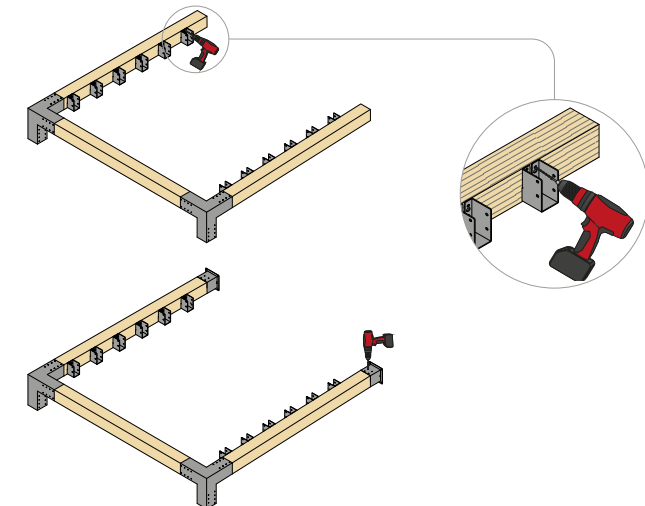

04
Montar os dois porta-pilares nas extremidades

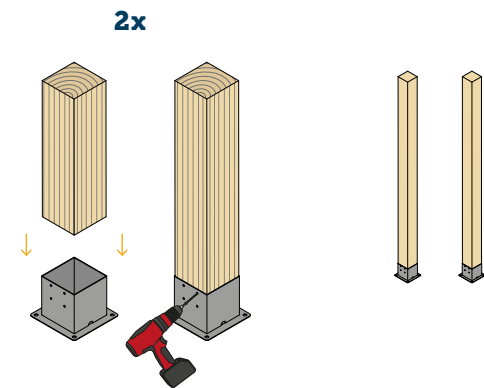



05

Inserir as colunas com os porta-pilares na parte superior previamente montada

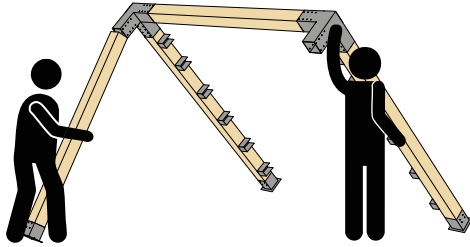

06

Fixar os elementos verticais, encostar a estrutura à parede e proceder à fixação tendo o cuidado de verificar a verticalidade e a esquadria dos elementos

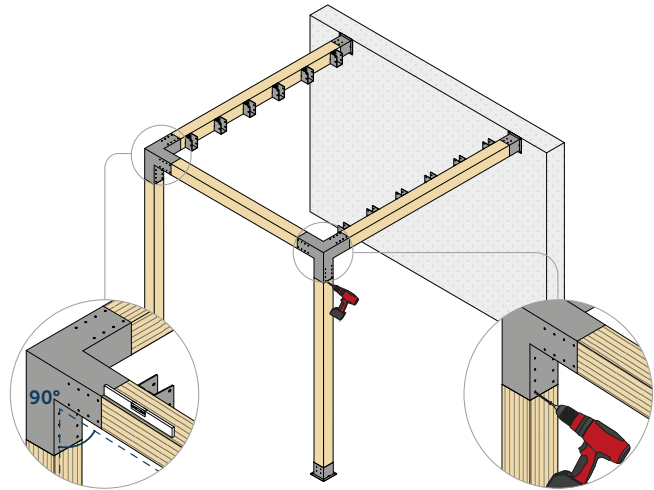

07

Fixar os porta-pilares à parede e ao solo

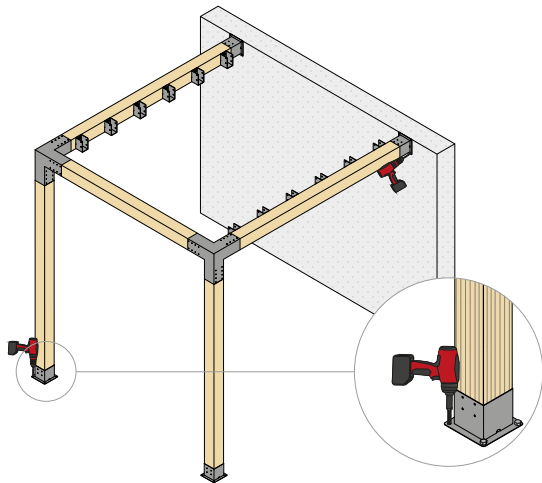

08

Completar a montagem da estrutura com a fixação dos barrotes

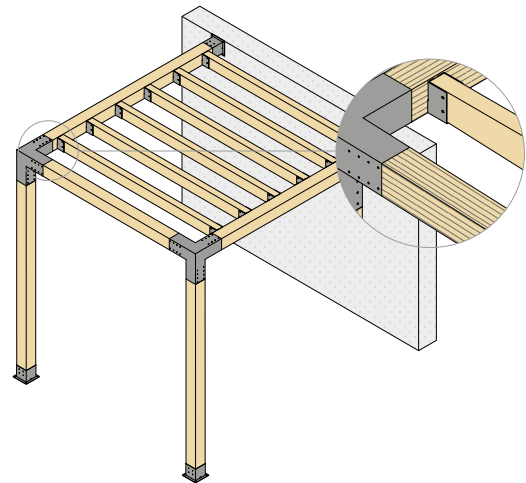

MONTAGEM

PÉRGULA DUPLA COM PROTEÇÃO SOLAR

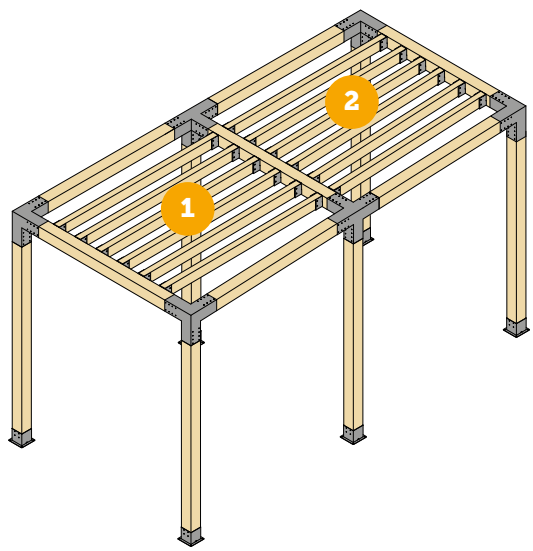

01 Colocar a parte 1 da pérgula no lugar

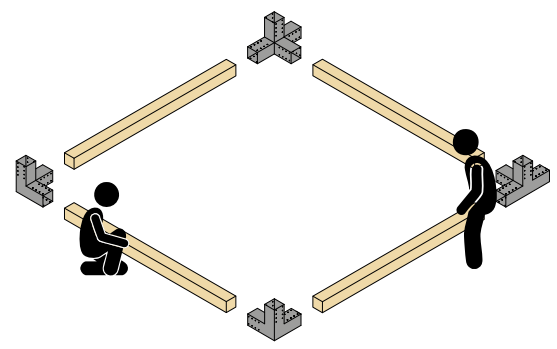

02a Montar primeiro os três elementos (de modo a formar um U)

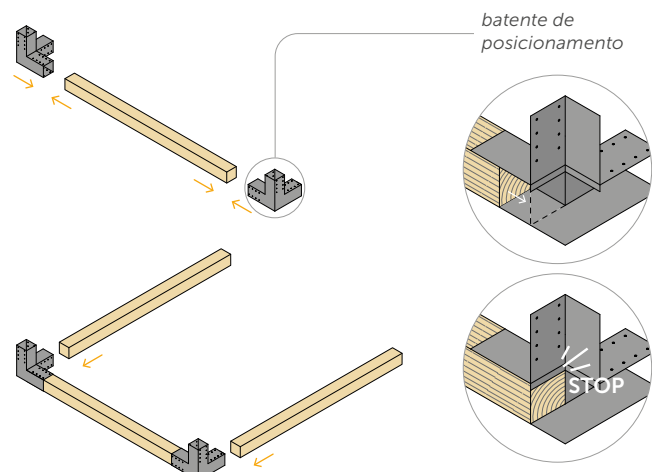

02b Fixar com aparafusadora

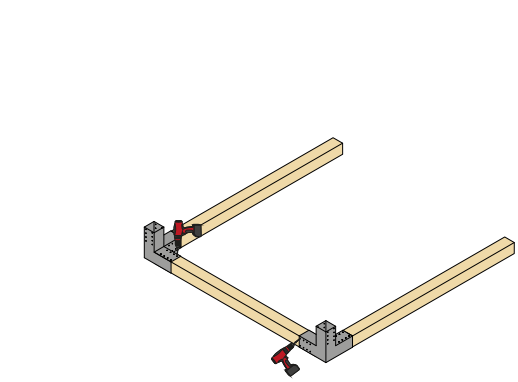

03a Completar a parte 1 como mostrado

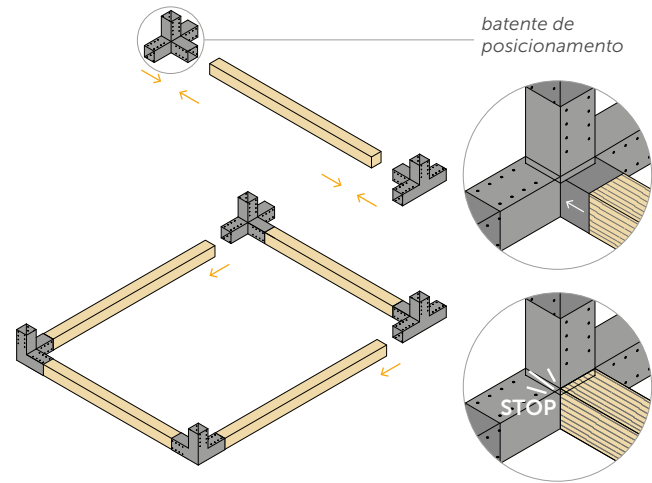

03b Proceder à fixação e rodar a parte montada em 180°

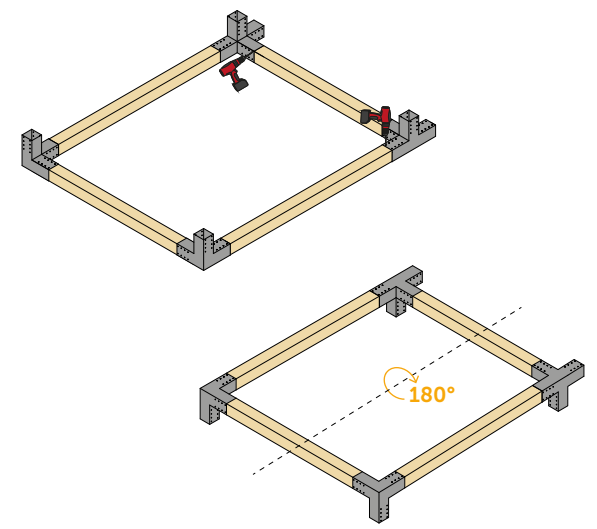



03c
 Fixar as sapatas nas vigas

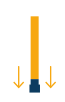
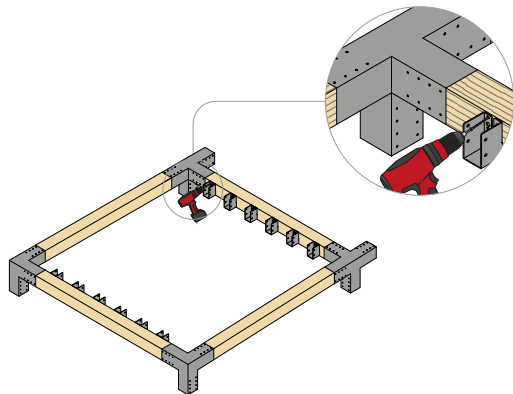

04
 Montar os porta-pilares

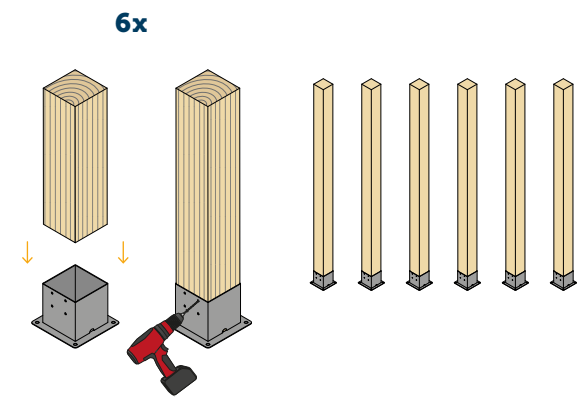

05
 Inserir as colunas com os porta-pilares na parte superior previamente montada

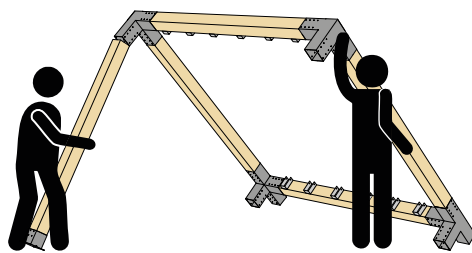

06
 Completar a operação com as duas colunas restantes

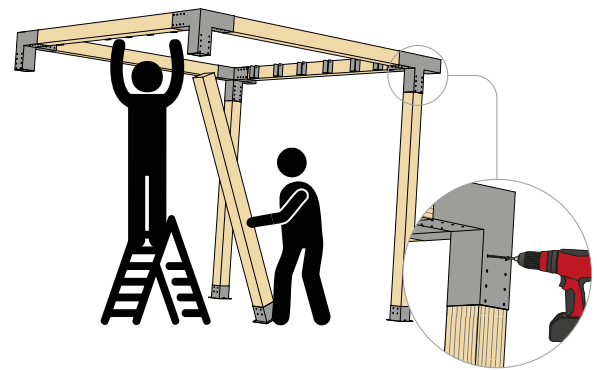

07
 Montar a parte 2

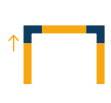
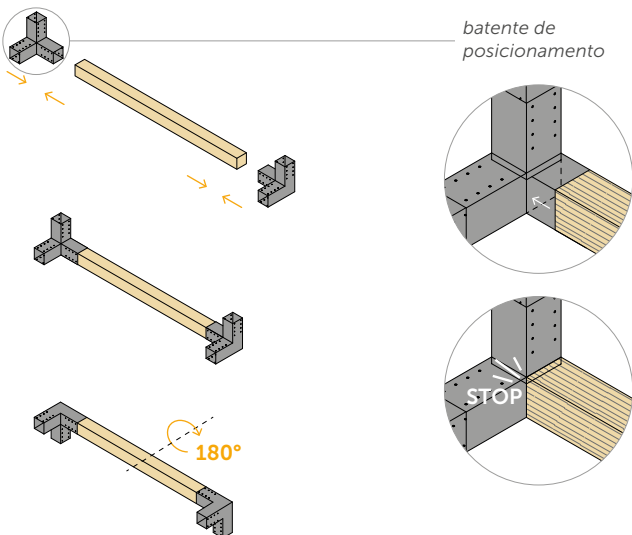

07a
 Montar a parte 2

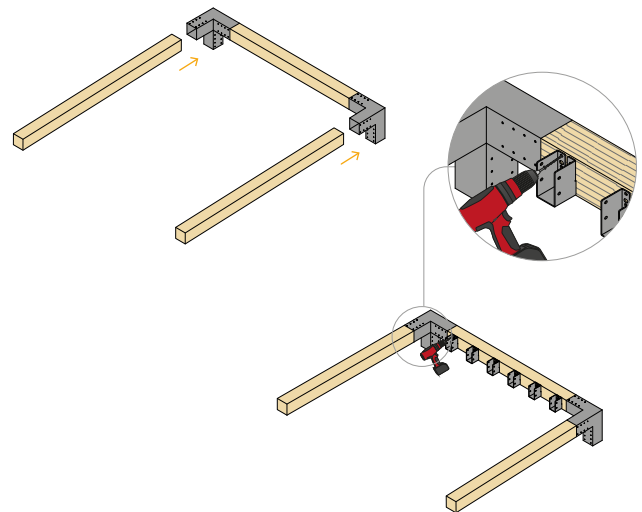

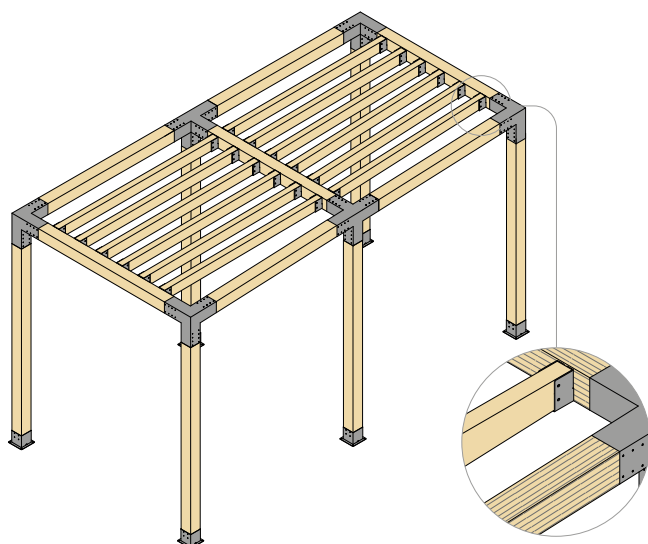
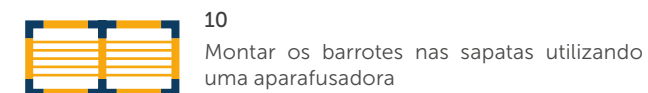
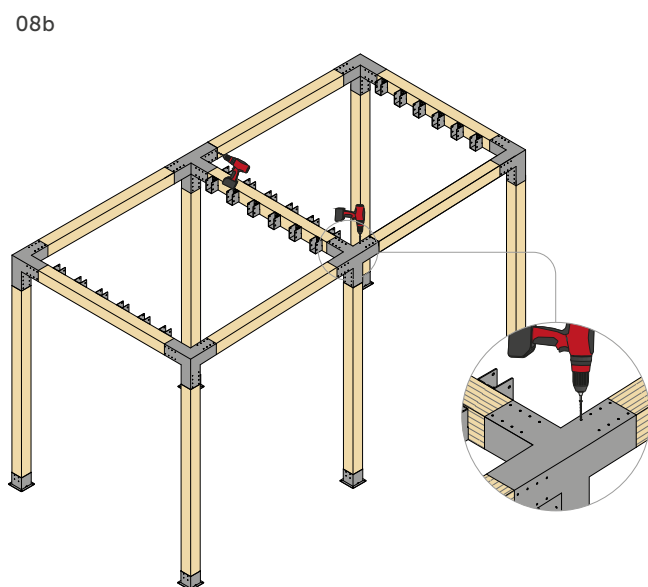
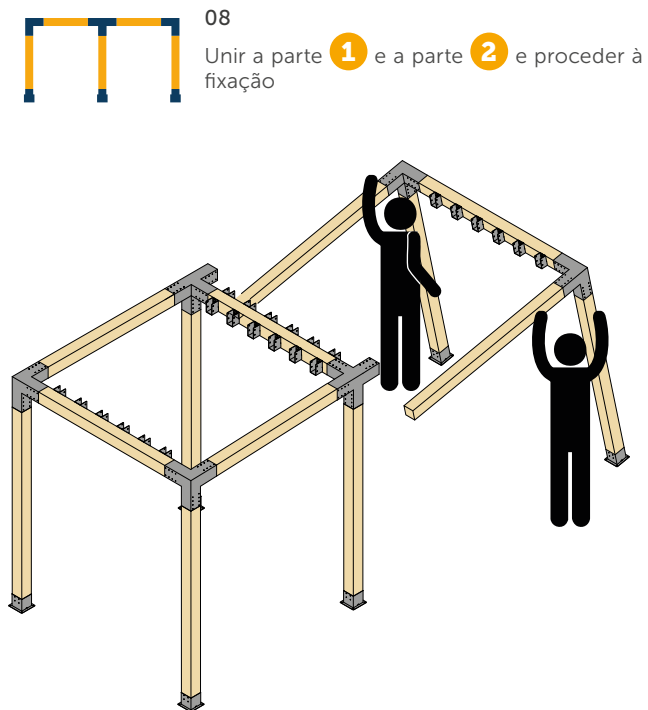
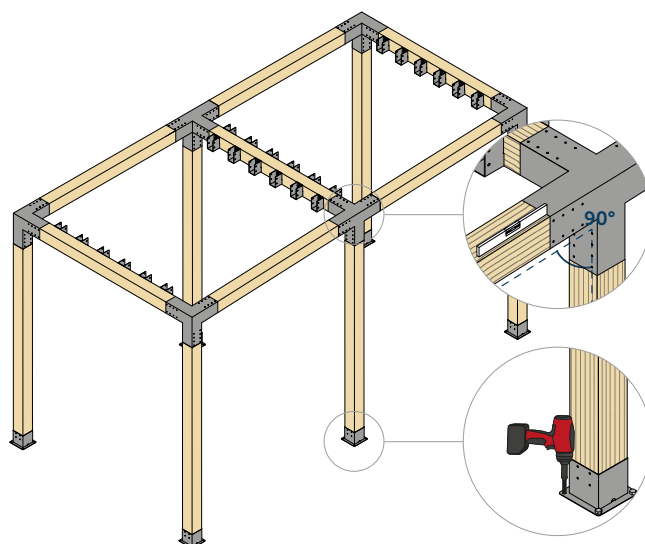
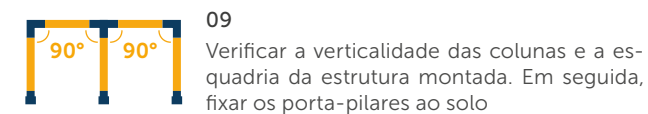
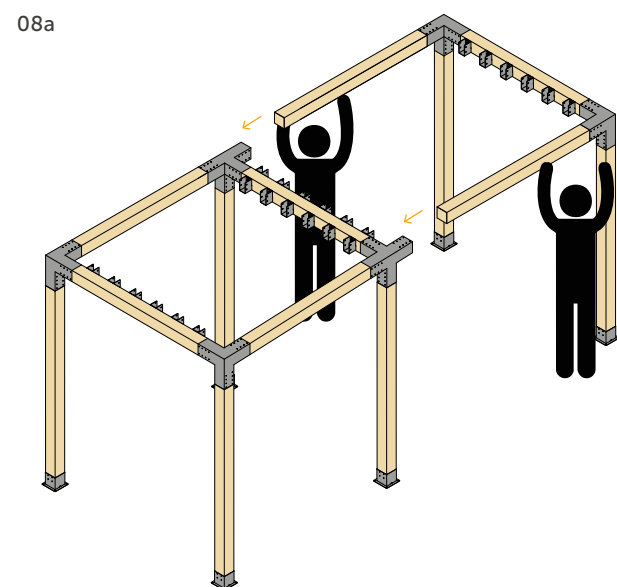
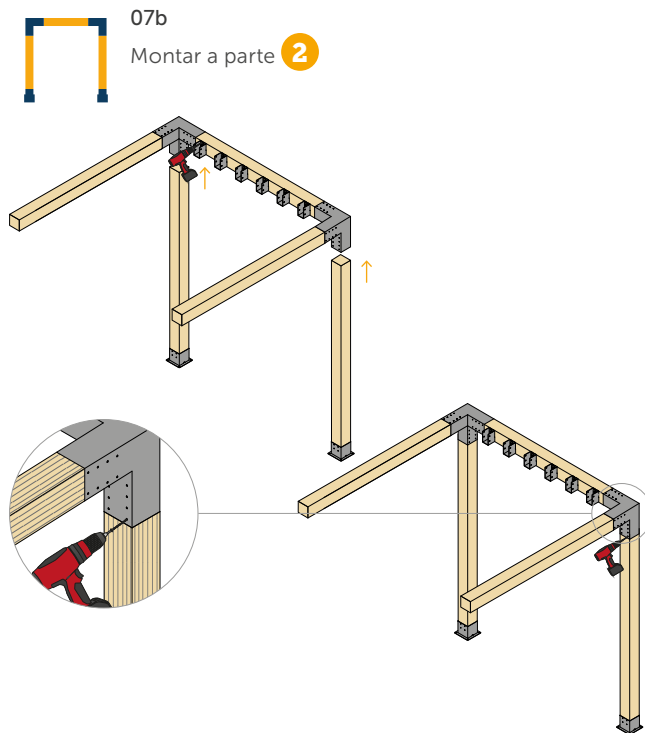

MONTAGEM

PÉRGULA DUPLA DE PAREDE COM PROTEÇÃO SOLAR

PARAFUSOS PARA MADEIRA
PARAFUSOS E CONECTORES PARA TERRAÇOS
PARAFUSOS PARA METAL
CHAPAS E ANGULARES
PORTA-PILARES E VEDAÇÕES
BUCHAS E ANCORANTES QUÍMICOS
MÉTRICO
MEMBRANAS
SELANTES, FITAS E PERFIS
VEDAÇÃO DE JANELAS
ACÚSTICA
ELEMENTOS PARA COBERTURA
EQUIPAMENTO

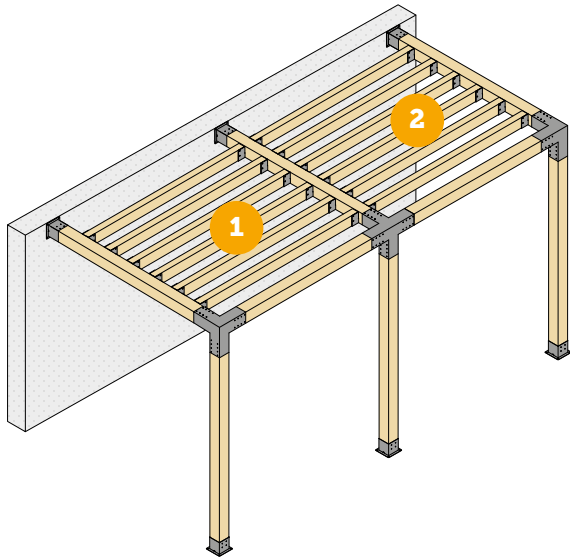

01 Colocar a parte 1 da pérgula no lugar

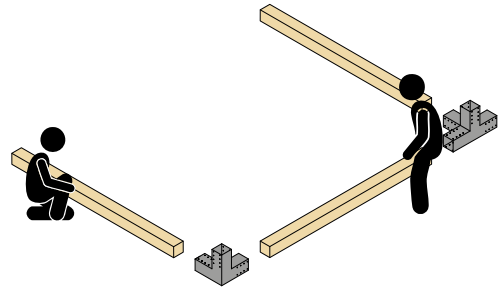

02a Montar primeiro os três elementos (de modo a formar um U)

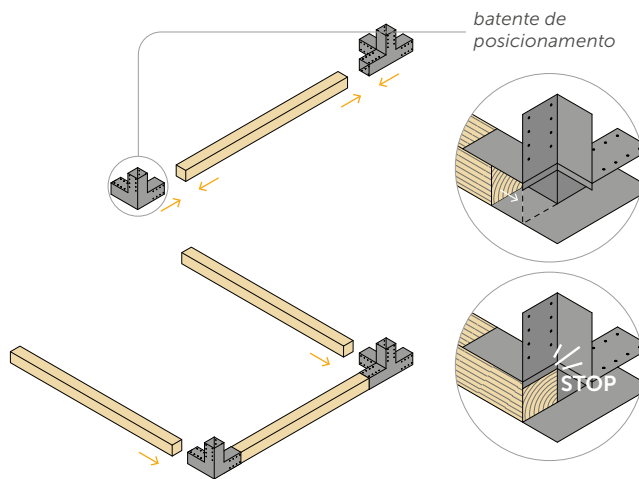

02b Fixar com aparafusadora

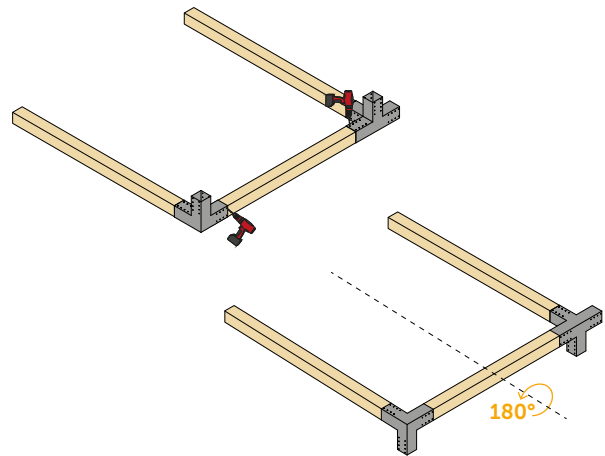

03 Completar a parte 1 como mostrado

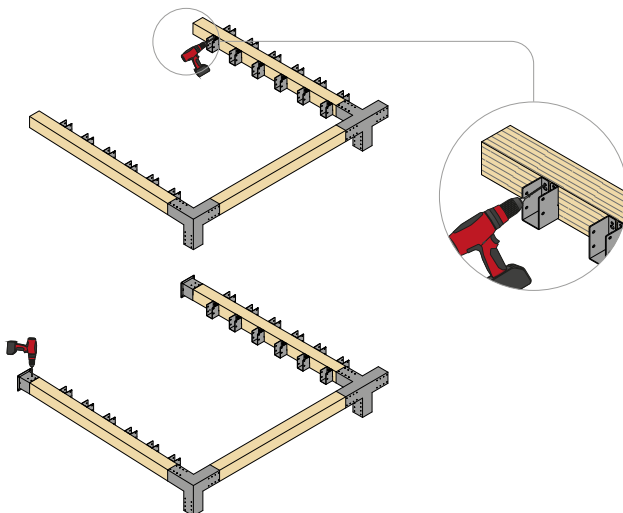

04 Montar os três porta-pilares nas extremidades

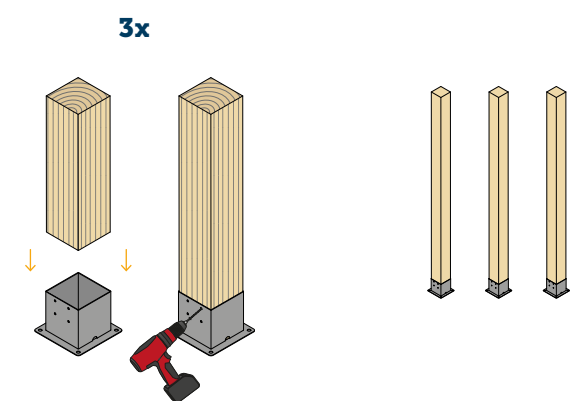



05

Colocar a parte **1** da pérgula no lugar

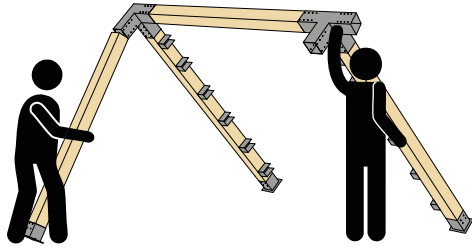

06

Montar a parte **2**

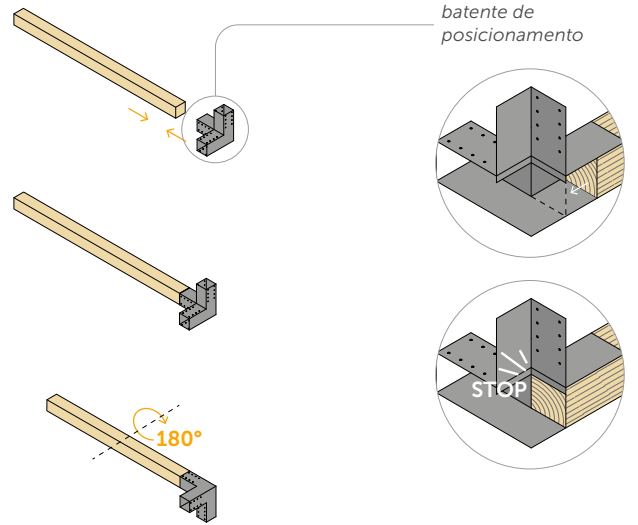

07

Montar primeiro os três elementos (de modo a formar um U)

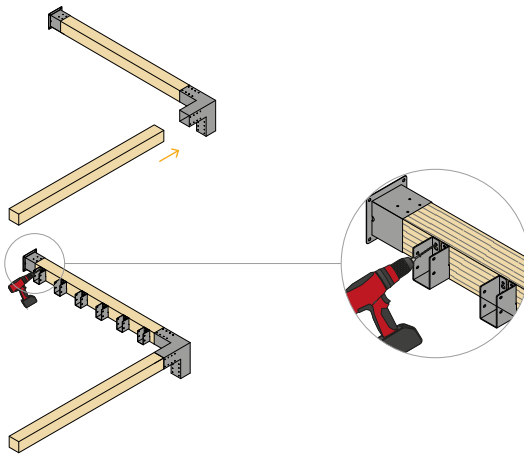

08

Fixar com aparafusadora

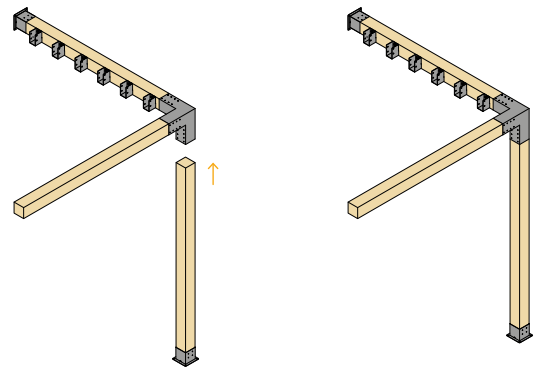

09

Fixar temporariamente a parte **1** da estrutura à parede e aproximar a parte **2** fixando-a em conjunto

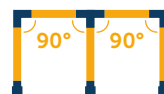
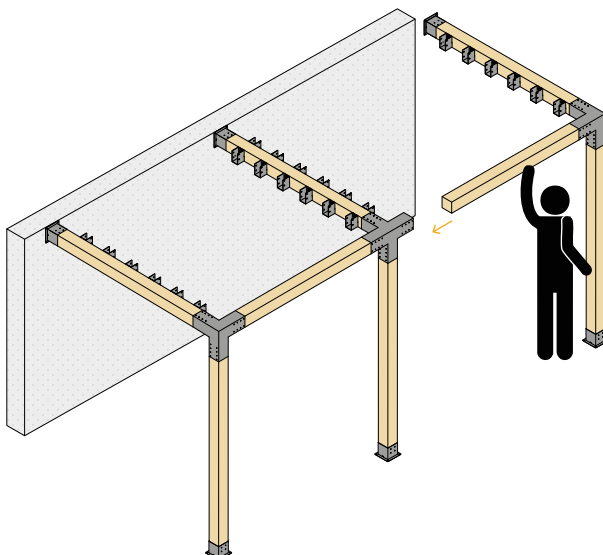

10

Montar os barros nas sapatas utilizando uma aparafusadora

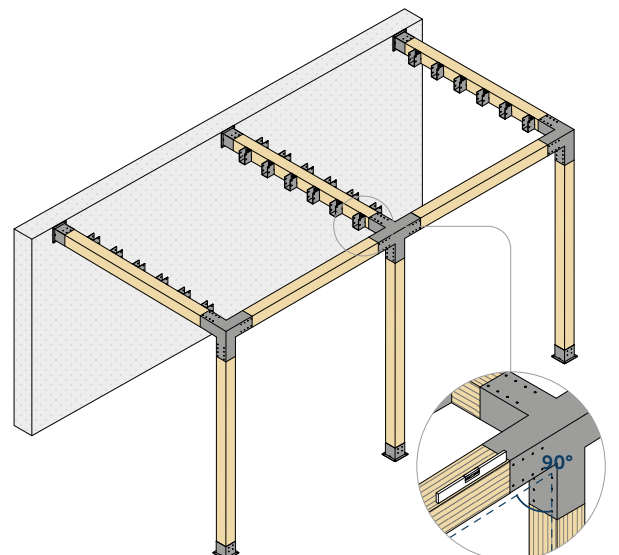



09

Fixar os porta-pilares à parede e ao solo

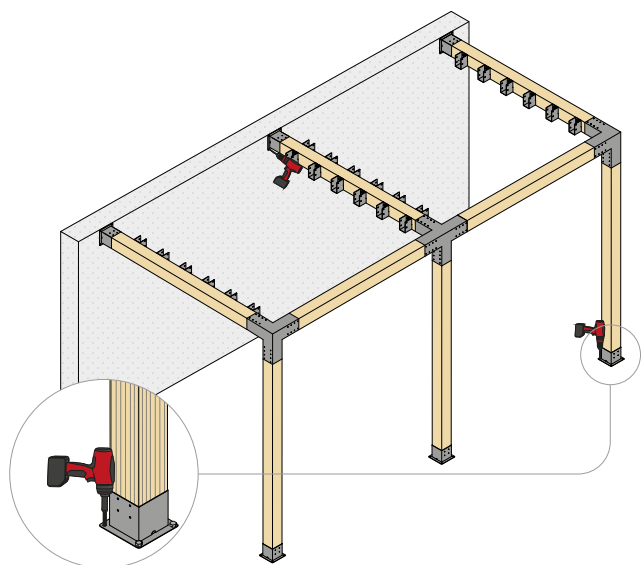

10

Montar os barrotes nas sapatas utilizando uma aparafusadora

